

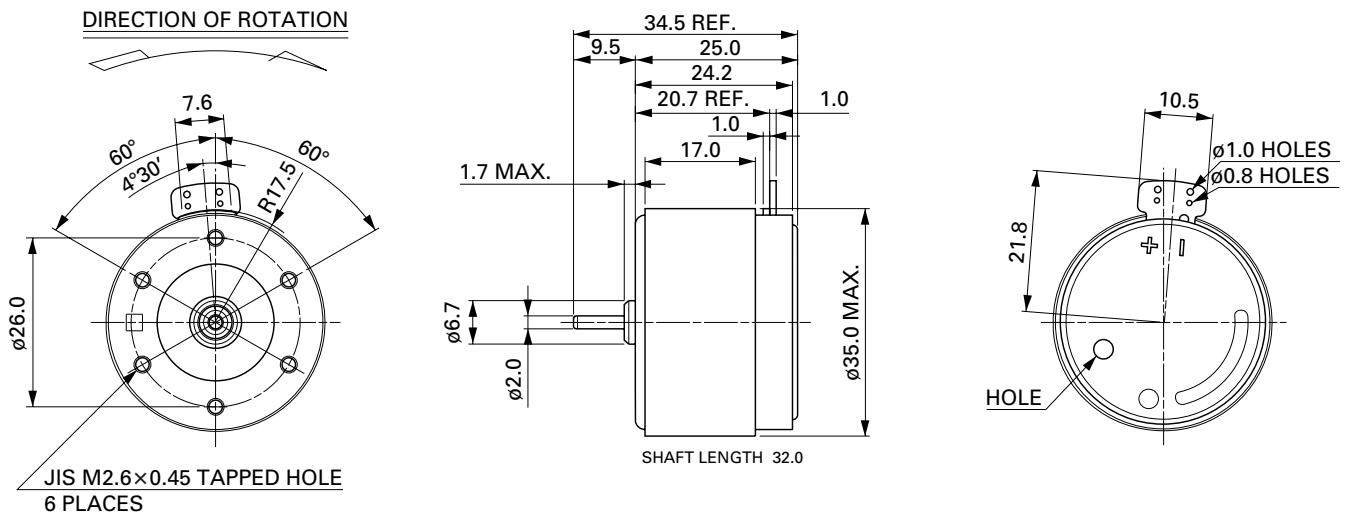

MODEL	RATED VOLTAGE	WORKING VOLTAGE	RATED LOAD		RATED SPEED	RATED LOAD CURRENT	LOAD FLUCTUATION(TYP)	STARTING TORQUE(MIN)	
	V	V	mN-m	g-cm	r/min	mA(TYP)	r/min / g-cm	mN-m	g-cm
EG-530AD-6F (6B)	6	4.2 ~ 7.5	0.78	8.0	2400±2%	132	9.0	3.72at4.2V	38at4.2V
EG-530AD-9F (9B)	9	6 ~ 11	0.78	8.0	2400±2%	92	9.0	4.90at6.0V	50at6.0V
EG-530AD-2F (2B)	12	8.4 ~ 15.0	0.78	8.0	2400±2%	73	9.0	5.88at8.4V	60at8.4V

UNIT: MILLIMETERS



EG-530AD-9F(9B) 6.0V/9.0V/11.0V

EG-530AD-2F(2B) 8.4V/12.0V/15.0V

