

# DNP015

## Green Mode Fairchild Power Switch (FPS™)

### Features

#### mWSaver™ Technology

- Achieves Low No-Load Power Consumption: < 40 mW at 230 V<sub>AC</sub> (EMI Filter Loss Included)
- Meets 2013 ErP Standby Power Regulation (< 0.5 W Consumption with 0.25 W Load) for ATX Power and LCD TV Power
- Eliminates X-Cap Discharge Resistor Loss with AX-CAP® Technology
- Linearly Decreased Switching Frequency at Light-Load Condition and Advanced Burst Mode Operation at No-Load Condition
- 700 V High-Voltage JFET Startup Circuit to Eliminate Startup Resistor Loss

#### Highly Integrated with Rich Features

- Internal Avalanche-Rugged 700 V SenseFET
- Built-in 5 ms Soft-Start
- Peak-Current-Mode Control
- Cycle-by-Cycle Current Limiting
- Leading-Edge Blanking (LEB)
- Synchronized Slope Compensation
- Proprietary Asynchronous Jitter to Reduce EMI

#### Advanced Protection

- Internal Overload / Open-Loop Protection (OLP)
- V<sub>DD</sub> Under-Voltage Lockout (UVLO)
- V<sub>DD</sub> Over-Voltage Protection (OVP)
- Constant Power Limit (Full AC Input Range)
- Internal Latch Protection (OLP, V<sub>DD</sub> OVP, OTP)
- Internal OTP Sensor with Hysteresis

### Description

The DNP015 is a next-generation, Green Mode Fairchild Power Switch (FPS™) that incorporates Fairchild's innovative mWSaver™ technology, which dramatically reduces standby and no-load power consumption, enabling conformance to all worldwide Standby Mode efficiency guidelines. It integrates an advanced current-mode pulse width modulator (PWM) and an avalanche-rugged 700 V SenseFET in a single package, allowing auxiliary power designs with higher standby efficiency, reduced size, improved reliability, and lower system cost than prior solutions.

Fairchild Semiconductor's mWSaver™ technology offers best-in-class minimum no-load and light-load power consumption. An innovative Ax-CAP® method, one of the five proprietary mWSaver™ technologies, minimizes losses in the EMI filter stage by eliminating the X-cap discharge resistors while meeting IEC61010-1 safety requirements. mWSaver™ Green Mode gradually decreases switching frequency as load decreases to minimize switching losses.

Proprietary asynchronous jitter decreases EMI emission and built-in synchronized slope compensation allows stable peak-current-mode control over a wide range of input voltage. The proprietary internal line compensation ensures constant output power limit over the entire universal line voltage range.

Requiring a minimum number of external components, DNP015 provides a basic platform that is well suited for the cost-effective flyback converter design with low standby power consumption.

### Applications

General-purpose switched-mode power supplies (SMPS) and flyback power converters, including:

- Auxiliary Power Supply for PC, Server, LCD TV, and Game Console
- SMPS for VCR, SVR, STB, DVD, and DVCD Player, Printer, Facsimile, and Scanner
- General Adapter
- LCD Monitor Power / Open-Frame SMPS

### Ordering Information

Part Number	SenseFET	Operating Temperature Range	Package	Packing Method
DNP015	3 A / 700 V	-40°C to +105°C	8-Pin, Dual In-Line Package (DIP)	Tube

### Application Diagram

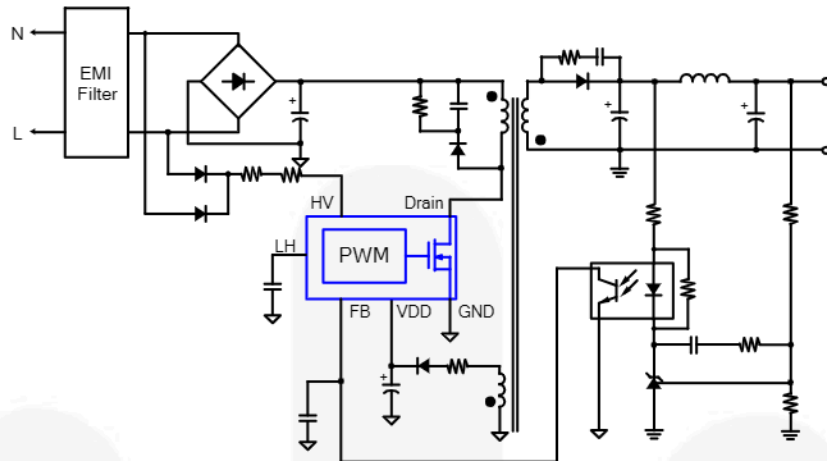

Figure 1. Typical Flyback Application

### Output Power Table<sup>(1)</sup>

Product	230V <sub>AC</sub> ± 15% <sup>(2)</sup>		85-265V <sub>AC</sub>	
	Adapter <sup>(3)</sup>	Open Frame <sup>(4)</sup>	Adapter <sup>(3)</sup>	Open Frame <sup>(4)</sup>
DNP015	17.5 W	25 W	13 W	19 W

#### Notes:

1. The maximum output power can be limited by junction temperature.
2. 230 V<sub>AC</sub> or 100 / 115 V<sub>AC</sub> with voltage doublers.
3. Typical continuous power in a non-ventilated enclosed adapter with sufficient drain pattern of printed circuit board (PCB) as a heat sink, at 50°C ambient.
4. Maximum practical continuous power in an open-frame design with sufficient drain pattern of printed circuit board (PCB) as a heat sink, at 50°C ambient.

### Block Diagram

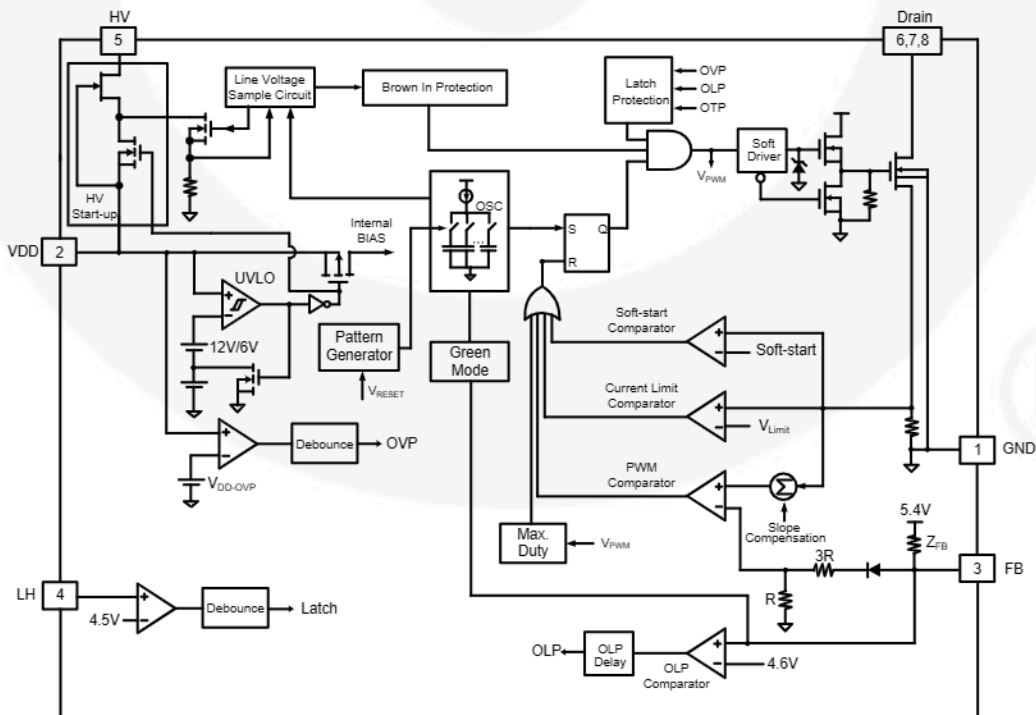
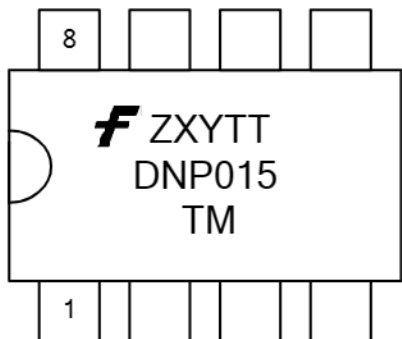

Figure 2. Internal Block Diagram

## Pin Configuration



*F* – Fairchild logo  
*Z* – Plant code  
*X* – 1-digit year code  
*Y* – 1-digit week code  
*TT* – 2-digit die run code  
*T* – Package type (N:DIP)  
*M* – Manufacture flow code

Figure 3. Pin Configuration

## Pin Definitions

Pin #	Name	Description
1	GND	<b>Ground.</b> This pin internally connects to the SenseFET source and signal ground of the PWM controller.
2	VDD	<b>Supply Voltage of the IC.</b> The holdup capacitor typically connects from this pin to ground. A rectifier diode in series with the transformer auxiliary winding connects to this pin to supply bias during normal operation.
3	FB	<b>Feedback.</b> The signal from the external compensation circuit connects to this pin. The PWM duty cycle is determined by comparing the signal on this pin and the internal current-sense signal.
4	LH	<b>Latch.</b> This pin is utilized for pull-HIGH latch protection by the external circuit, depending on the application.
5	HV	<b>Startup.</b> Typically, resistors in series with diodes from the AC line connect to this pin to supply internal bias and to charge the external capacitor connected between the VDD pin and the GND pin during startup. This pin is also used to sense the line voltage for brown-in and to detect AC line disconnection.
6	Drain	<b>SenseFET Drain.</b> This pin is designed to directly drive the transformer.
7		
8		

## Absolute Maximum Ratings

Stresses exceeding the absolute maximum ratings may damage the device. The device may not function or be operable above the recommended operating conditions and stressing the parts to these levels is not recommended. In addition, extended exposure to stresses above the recommended operating conditions may affect device reliability. The absolute maximum ratings are stress ratings only.

Symbol	Parameter	Min.	Max.	Unit
V <sub>DRAIN</sub>	Drain Pin Voltage <sup>(5,6)</sup>		700	V
I <sub>DM</sub>	Drain Current Pulsed <sup>(7)</sup>		12	A
E <sub>AS</sub>	Single-Pulsed Avalanche Energy <sup>(8)</sup>		230	mJ
V <sub>DD</sub>	DC Supply Voltage		30	V
V <sub>FB</sub>	FB Pin Input Voltage	-0.3	7.0	V
V <sub>LH</sub>	LH Pin Input Voltage	-0.3	7.0	V
V <sub>HV</sub>	HV Pin Input Voltage		700	V
P <sub>D</sub>	Power Dissipation (T <sub>A</sub> < 50°C)		1.55	W
T <sub>J</sub>	Operating Junction Temperature	-40	Internally Limited <sup>(9)</sup>	°C
T <sub>STG</sub>	Storage Temperature Range	-55	+150	°C
T <sub>L</sub>	Lead Soldering Temperature (Wave Soldering or IR, 10 Seconds)		+260	°C
ESD	Electrostatic Discharge Capability, All Pins Except HV Pin	Human Body Model: JESD22-A114	5.50	kV
		Charged Device Model: JESD22-C101	2.00	
	Electrostatic Discharge Capability, All Pins Including HV Pin	Human Body Model: JESD22-A114	3.00	
		Charged Device Model: JESD22-C101	1.25	

### Notes:

- All voltage values, except differential voltages, are given with respect to the network ground terminal.
- Stresses beyond those listed under Absolute Maximum Ratings may cause permanent damage to the device.
- Repetitive rating: pulse width is limited by maximum junction temperature.
- L = 51 mH, starting T<sub>J</sub> = 25°C.
- Internally limited by Over-Temperature Protection (OTP), refer to T<sub>OTP</sub>.

## Recommended Operating Conditions

The Recommended Operating Conditions table defines the conditions for actual device operation. Recommended operating conditions are specified to ensure optimal performance to the datasheet specifications. Fairchild does not recommend exceeding them or designing to Absolute Maximum Ratings.

Symbol	Parameter	Min.	Max.	Unit
R <sub>HV</sub>	Resistor Connected to HV Pin for Full Range Input Detection	150	250	kΩ

## Thermal Resistance Table

Symbol	Parameter	Typ.	Unit
θ <sub>JA</sub>	Junction-to-Air Thermal Resistance	81	°C/W
ψ <sub>JT</sub>	Junction-to-Package Thermal Resistance <sup>(10)</sup>	25	°C/W

### Note:

- Measured on the package top surface.

## Electrical Characteristics

$V_{DD}=15\text{ V}$  and  $T_A=25^\circ\text{C}$  unless otherwise specified.

Symbol	Parameter	Condition	Min.	Typ.	Max.	Unit
<b>SenseFET Section<sup>(11)</sup></b>						
$BV_{DSS}$	Drain-Source Breakdown Voltage	$V_{GS} = 0\text{ V}$ , $I_D=250\ \mu\text{A}$ , $T_J=25^\circ\text{C}$	700			V
$I_{DSS}$	Zero-Gate-Voltage Drain Current	$V_{DS} = 700\text{ V}$ , $V_{GS} = 0\text{ V}$			50	$\mu\text{A}$
		$V_{DS} = 560\text{ V}$ , $V_{GS} = 0\text{ V}$ , $T_C = 125^\circ\text{C}$			200	
$R_{DS(ON)}$	Drain-Source On-State Resistance <sup>(12)</sup>	$V_{GS} = 10\text{ V}$ , $I_D = 1\text{ A}$		4.00	4.75	$\Omega$
$C_{ISS}$	Input Capacitance	$V_{GS} = 0\text{ V}$ , $V_{DS} = 25\text{ V}$ , $f = 1\text{ MHz}$		315	410	pF
$C_{OSS}$	Output Capacitance	$V_{GS} = 0\text{ V}$ , $V_{DS} = 25\text{ V}$ , $f = 1\text{ MHz}$		47	61	pF
$C_{RSS}$	Reverse Transfer Capacitance	$V_{GS} = 0\text{ V}$ , $V_{DS} = 25\text{ V}$ , $f = 1\text{ MHz}$		9.0	24.0	pF
$t_{d(on)}$	Turn-On Delay	$V_{DS} = 350\text{ V}$ , $I_D = 1.0\text{ A}$		11.2	33.0	ns
$t_r$	Rise Time	$V_{DS} = 350\text{ V}$ , $I_D = 1.0\text{ A}$		34	78	ns
$t_{d(off)}$	Turn-Off Delay	$V_{DS} = 350\text{ V}$ , $I_D = 1.0\text{ A}$		28.2	67.0	ns
$t_f$	Fall Time	$V_{DS} = 350\text{ V}$ , $I_D = 1.0\text{ A}$		32	74	ns
<b>Control Section</b>						
<b>VDD Section</b>						
$V_{DD-ON}$	UVLO Start Threshold Voltage		11	12	13	V
$V_{DD-OFF1}$	UVLO Stop Threshold Voltage		5	6	7	V
$V_{DD-OFF2}$	Threshold Voltage of VDD Pin for HV Device Turn-On at Latch Mode		8	9	10	V
$V_{DD-LH}$	Threshold Voltage on VDD Pin for Latch-Off Release Voltage		3.5	4.0	4.5	V
$I_{DD-ST}$	Startup Supply Current	$V_{DD-ON} - 0.16\text{ V}$			30	$\mu\text{A}$
$I_{DD-OP1}$	Operating Supply Current with Normal Switching Operation	$V_{DD}=15\text{ V}$ , $V_{FB}=3\text{ V}$			3.6	mA
$I_{DD-OP2}$	Operating Supply Current without Switching Operation	$V_{DD}=15\text{ V}$ , $V_{FB}=1\text{ V}$			1.6	mA
$V_{DD-OVP}$	$V_{DD}$ Over-Voltage Protection <sup>(11)</sup>			28		V
$t_{D-VDDOVP}$	$V_{DD}$ Over-Voltage Protection Debounce Time <sup>(11)</sup>			150		$\mu\text{s}$
<b>HV Section</b>						
$I_{HV}$	Supply Current Drawn from HV Pin	$HV=120\text{ V}_{DC}$ , $V_{DD}=0\text{ V}$ with $10\ \mu\text{F}$	1.5		5.0	mA
$I_{HV-LC}$	Leakage Current after Startup	$HV=700\text{ V}$ , $V_{DD}=V_{DD-OFF1}+1\text{ V}$			10	$\mu\text{A}$
$V_{AC-ON}$	Brown-in Threshold Level ( $V_{DC}$ )	DC Voltage Applied to HV Pin through $200\text{ k}\Omega$	102	110	118	V
$K_{DISCHARGE}$	X-Cap Discharge Threshold	$R=200\text{ k}\Omega$ to HV Pin	60			%
$t_{AC-OFF}$	AC-Off Debounce Time for HV Discharge Function <sup>(11)</sup>			160		ms

Continued on the following page...

## Electrical Characteristics

$V_{DD}=15\text{ V}$  and  $T_A=25^\circ\text{C}$  unless otherwise specified.

Symbol	Parameter	Condition	Min.	Typ.	Max.	Unit
<b>Oscillator Section</b>						
$f_{OSC}$	Frequency in Nominal Mode	Center Frequency	94	100	106	kHz
		Hopping Range	$\pm 4.0$	$\pm 6.0$	$\pm 8.0$	
$t_{HOP}$	Hopping Period <sup>(11)</sup>			20		ms
$f_{OSC-G}$	Green-Mode Frequency		20	23	26	kHz
$DCY_{MAX}$	Maximum Duty Cycle		80			%
$f_{DV}$	Frequency Variation vs. $V_{DD}$ Deviation	$V_{DD}=11\text{ V to }22\text{ V}$			5	%
$f_{DT}$	Frequency Variation vs. Temperature Deviation <sup>(11)</sup>	$T_A=-40\text{ to }105^\circ\text{C}$			5	%
<b>Feedback Input Section</b>						
$A_V$	Internal Voltage Dividing Factor of FB Pin <sup>(11)</sup>		1/4.5	1/4.0	1/3.5	V/V
$Z_{FB}$	Pull-Up Impedance of FB Pin		24	29	34	k $\Omega$
$V_{FB-OPEN}$	FB Pin Pull-Up Voltage	FB Pin Open	5.2	5.4	5.6	V
$V_{FB-OLP}$	FB Voltage Threshold to Trigger Open-Loop Protection		4.3	4.6	4.9	V
$t_{D-OLP}$	Delay of FB Pin Open-Loop Protection		46	56	66	ms
$V_{FB-N}$	FB Voltage Threshold to Exit Green Mode	$V_{FB}$ Rising	2.4	2.6	2.8	V
$V_{FB-G}$	FB Voltage Threshold to Enter Green Mode	$V_{FB}$ Falling		$V_{FB-N} - 0.1$		V
$V_{FB-ZDC}$	FB Voltage Threshold to Enter Zero-Duty State	$V_{FB}$ Falling	2.0	2.1	2.2	V
$V_{FB-ZDCR}$	FB Voltage Threshold to Exit Zero-Duty State	$V_{FB}$ Rising		$V_{FB-ZDC} + 0.1$		V
<b>LH Pin Section</b>						
$V_{LATCH}$	Latch Comparator Reference Voltage		4.1	4.4	4.7	V
$t_{LATCH}$	Latch Mode Debounce Time				35	$\mu\text{s}$
$V_{LH-OPEN}$	LH Pin Open Voltage		3.0	3.5	4.0	V
<b>Current-Sense Section<sup>(13)</sup></b>						
$I_{LMT-FL}$	Flat Threshold Level of Current Limit	Duty>40%	0.85	1.00	1.15	A
$I_{LMT-VA}$	Valley Threshold Level of Current Limit <sup>(11)</sup>	Duty=0%		$I_{LMT-FL} - 0.2$		A
$t_{PD}$	Current Limit Turn-Off Delay			100	200	ns
$t_{LEB}$	Leading-Edge Blanking Time		230	280	330	ns
$t_{SS}$	Soft-Start Time <sup>(11)</sup>			5		ms
<b>Over-Temperature Protection Section (OTP)</b>						
$T_{OTP}$	Junction Temperature Trigger OTP <sup>(11,14)</sup>			135		$^\circ\text{C}$
$\Delta T_{OTP}$	Hysteresis of OTP <sup>(11,15)</sup>			$T_{OTP}-25$		$^\circ\text{C}$

### Notes:

- Guaranteed by design; not 100% tested in production.
- Pulse test: pulse width  $\leq 300\ \mu\text{s}$ , duty  $\leq 2\%$ .
- These parameters, although guaranteed, are tested in wafer-sort process.
- When activated, the output is disabled and enters latch protection.
- The threshold temperature for enabling the output again and resetting the latch after over-temperature protection has been activated.

## Typical Characteristics

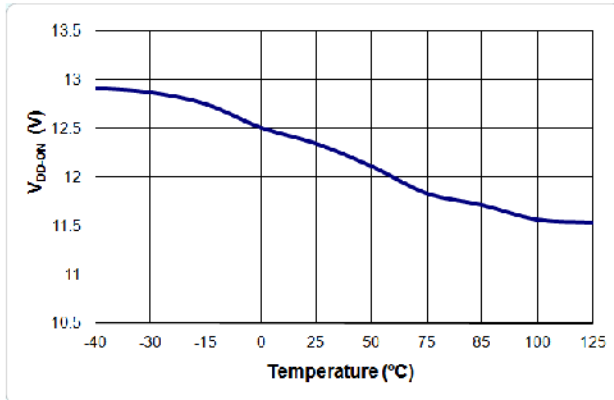

Figure 4. V<sub>DD-ON</sub> vs. Temperature

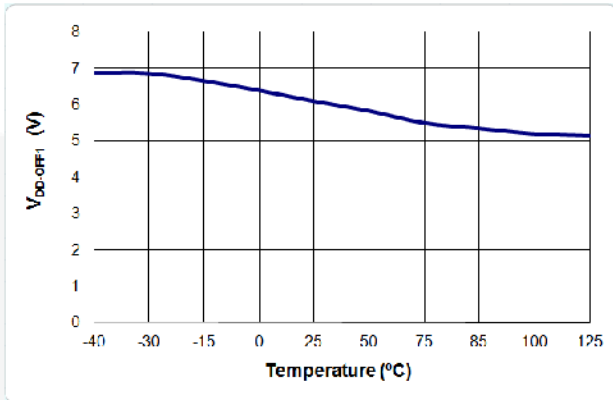

Figure 5. V<sub>DD-OFF1</sub> vs. Temperature

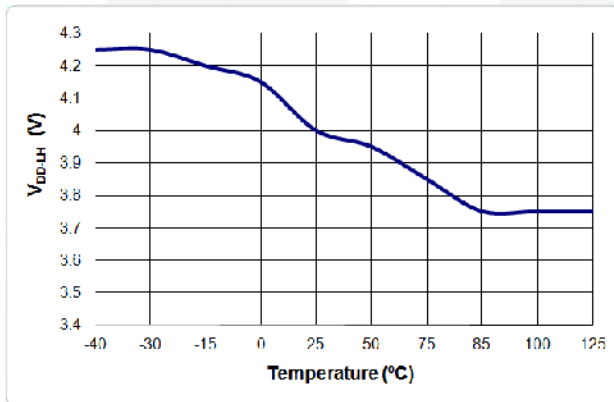

Figure 6. V<sub>DD-LH</sub> vs. Temperature

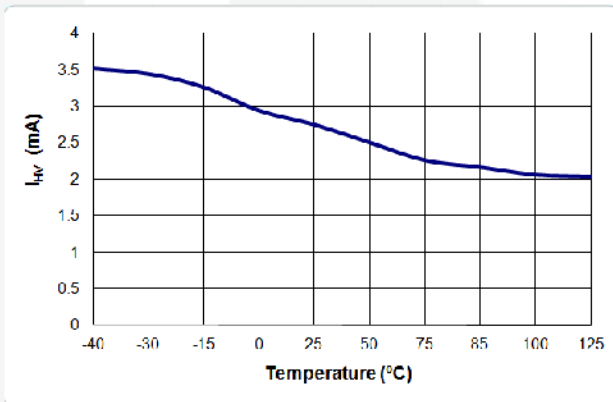

Figure 7. I<sub>HV</sub> vs. Temperature

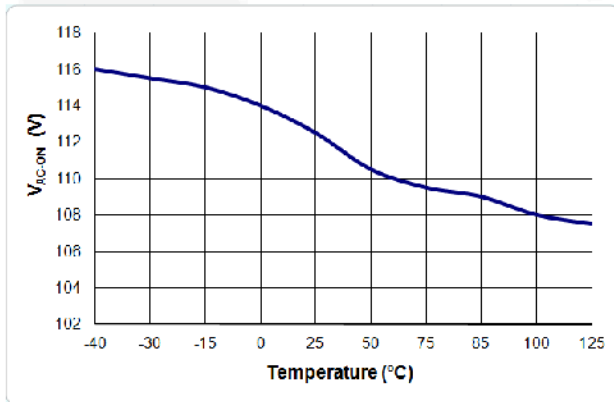

Figure 8. V<sub>AC-ON</sub> vs. Temperature

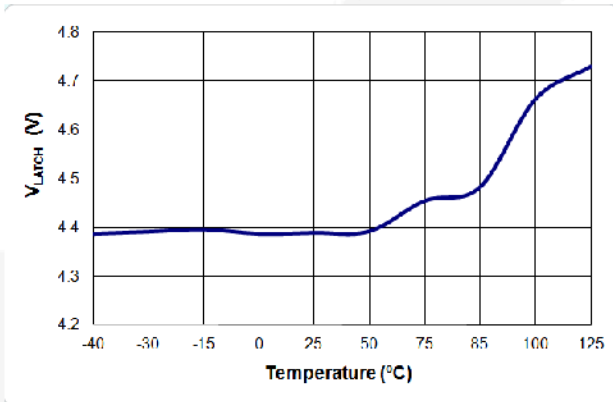

Figure 9. V<sub>LATCH</sub> vs. Temperature

## Typical Characteristics

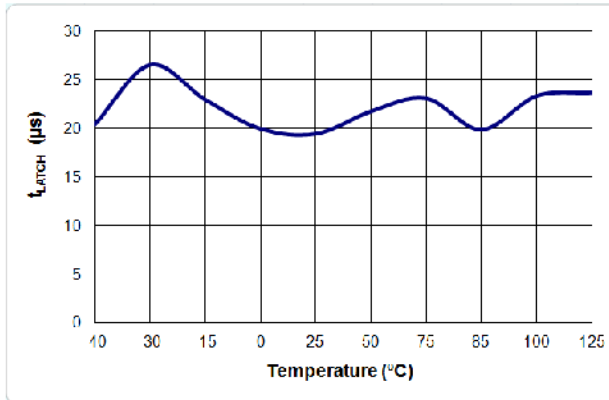

Figure 10.  $t_{LATCH}$  vs. Temperature

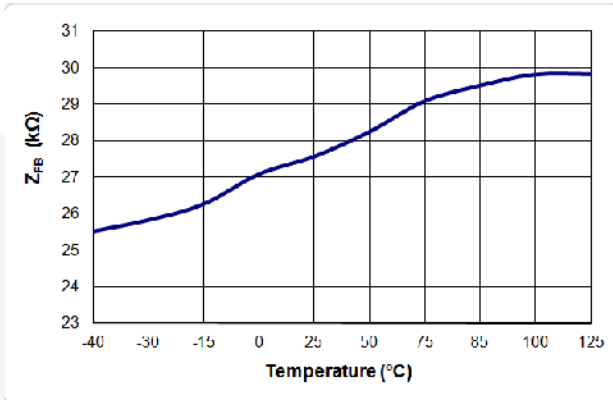

Figure 11.  $Z_{FB}$  vs. Temperature

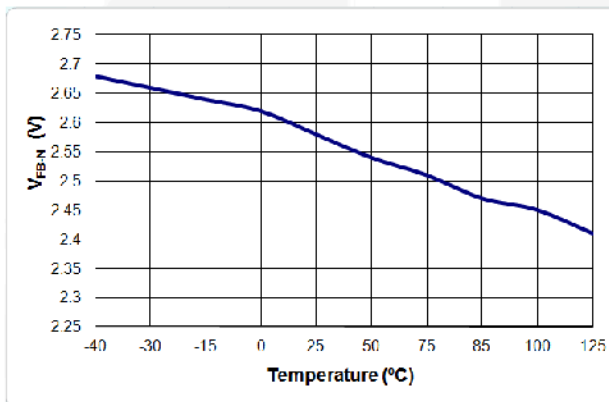

Figure 12.  $V_{FB-N}$  vs. Temperature

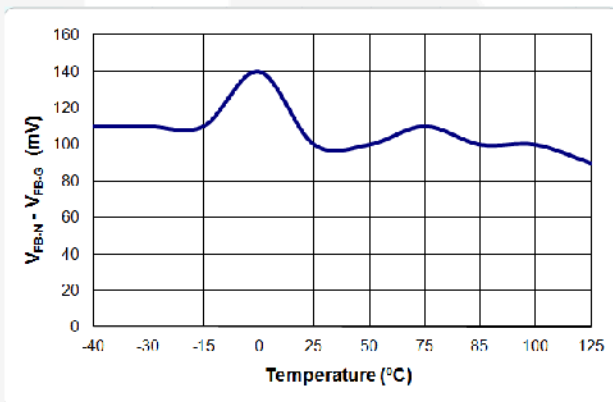

Figure 13.  $V_{FB-N} - V_{FB-G}$  vs. Temperature

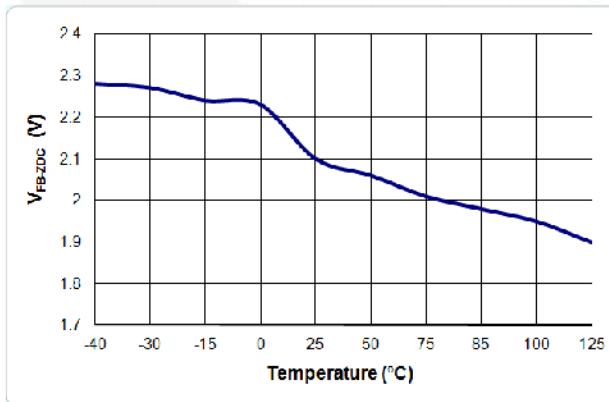

Figure 14.  $V_{FB-ZDC}$  vs. Temperature

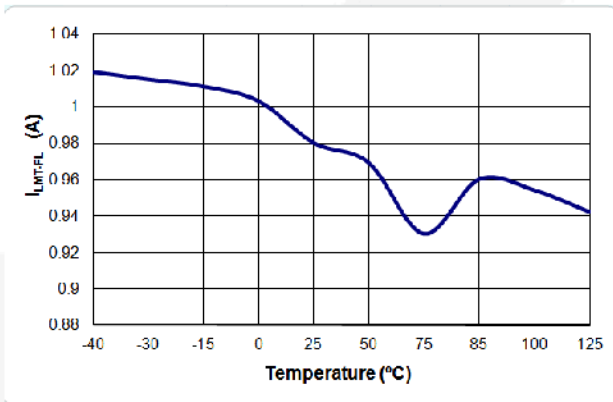

Figure 15.  $I_{LMT-FL}$  vs. Temperature

## Functional Description

### Startup Operation

The HV pin is typically connected to the AC line input through two external diodes and one resistor ( $R_{HV}$ ), as shown in Figure 16. When the AC line voltage is applied, the  $V_{DD}$  hold-up capacitor is charged by the line voltage through the diodes and resistor. After  $V_{DD}$  voltage reaches the turn-on threshold voltage ( $V_{DD-ON}$ ), the startup circuit charging the  $V_{DD}$  capacitor is switched off and  $V_{DD}$  is supplied by the auxiliary winding of the transformer. Once the DNP015 starts, it continues operation until  $V_{DD}$  drops below 6 V ( $V_{DD-OFF1}$ ). The IC startup time with a given AC line input voltage is:

$$t_{STARTUP} = R_{HV} \cdot C_{DD} \cdot \ln \frac{V_{AC-IN} \cdot \frac{2\sqrt{2}}{\pi}}{V_{AC-IN} \cdot \frac{2\sqrt{2}}{\pi} - V_{DD-ON}} \quad (1)$$

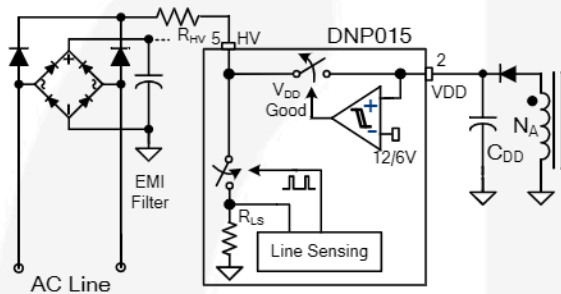

Figure 16. Startup Circuit

### Brown-in Function

The HV pin can detect the AC line voltage using a switched voltage divider that consists of external resistor ( $R_{HV}$ ) and internal resistor ( $R_{LS}$ ), as shown in Figure 16. The internal line-sensing circuit detects the real RMS value of the line voltage using a sampling circuit and peak-detection circuit. Because the voltage divider causes power consumption when it is switched on, the switching is driven by a signal with a very narrow pulse width to minimize power loss. The sampling frequency is adaptively changed according to the load condition to minimize power consumption in light-load condition.

Based on the detected line voltage, brown-in threshold is determined. Since the internal resistor ( $R_{LS}$ ) of the voltage divider is much smaller than  $R_{HV}$ , the thresholds are given as:

$$V_{BROWN-IN}(RMS) = \frac{R_{HV}}{200k} \cdot \frac{V_{AC-ON}}{\sqrt{2}} \quad (2)$$

### PWM Control

The DNP015 employs current-mode control, as shown in Figure 17. An opto-coupler (such as the H11A817A) and shunt regulator (such as the KA431) are typically used to implement the feedback network. Comparing the feedback voltage with the voltage across the  $R_{SENSE}$  resistor makes it possible to control the switching duty cycle. A synchronized positive slope is added to the

SenseFET current information to guarantee stable current-mode control over a wide range of input voltage. The built-in slope compensation stabilizes the current loop and prevents sub-harmonic oscillation.

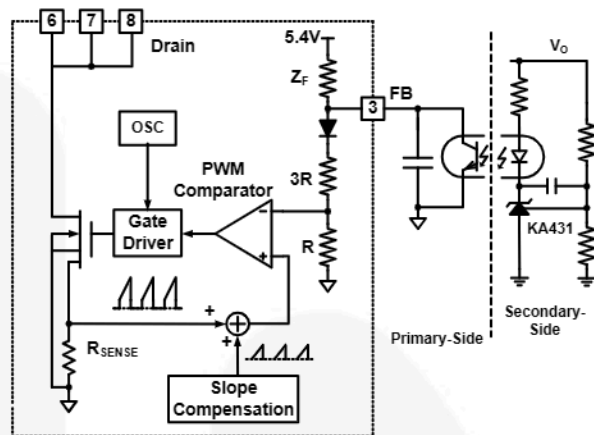

Figure 17. Current Mode Control

### Soft-Start

The internal soft-start circuit progressively increases the pulse-by-pulse current-limit level of the MOSFET during startup to establish the correct working conditions for transformers and capacitors, as shown in Figure 18. The current limit levels have nine steps, as shown in Figure 19. This prevents transformer saturation and reduces stress on the secondary diode during startup.

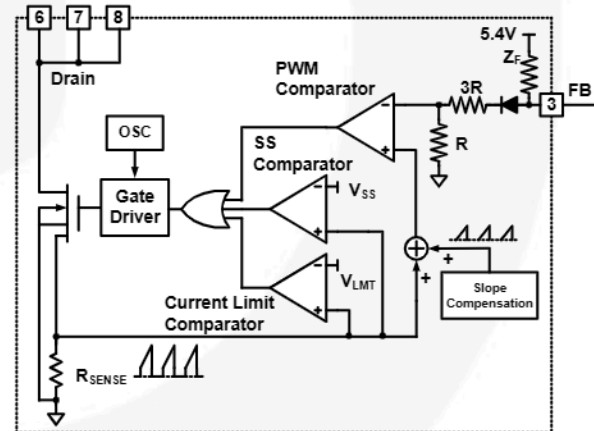

Figure 18. Soft-Start and Current-Limit Circuit

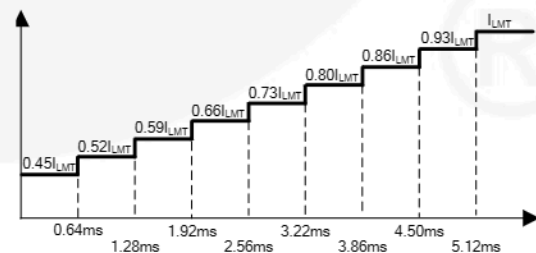

Figure 19. Current Limit Variation During Soft-Start

## H/L Line Compensation for Constant Power Limit

To maintain constant limited output power, regardless of the line voltage condition, a special current-limit profile with sample-and-hold is used (as shown in Figure 20). The current-limit level is sampled and held at the falling edge of the gate drive signal, as shown in Figure 21. Then the sampled current-limit level is used for the next switching cycle. The sample-and-hold function prevents sub-harmonic oscillation in current-mode control.

The current-limit level increases as the duty cycle increases, which reduces the current limit as duty cycle decreases. This allows a lower current-limit level for high-line voltage condition where the duty cycle is smaller than that of low line. Therefore, the limited maximum output power can remain constant even for a wide input voltage range.

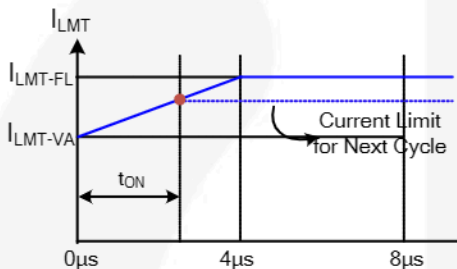

Figure 20.  $I_{LMT}$  vs. PWM Turn-On Time

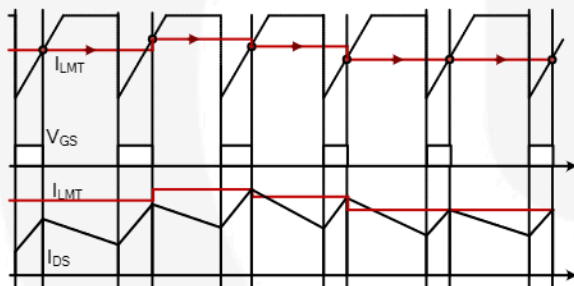

Figure 21. Current Limit Variation with Duty Cycle

## mWSaver™ Technology

### AX-CAP® Elimination of X-Cap Discharge Resistors

The EMI filter in the front end of the switched-mode power supply (SMPS) typically includes a capacitor across the AC line connector, as shown in Figure 22. Most of the safety regulations, such as UL1950 and IEC61010-1, require the capacitor be discharged to a safe level within a given time after being unplugged from the power outlet. Typically, a discharge resistor across the capacitor is used to ensure the capacitor is discharged naturally, which introduces power loss. As power level increases, the EMI filter capacitor tends to increase, requiring a smaller discharge resistor to maintain the same discharge time. This typically results in more power dissipation in high-power applications. The innovative AX-CAP technology intelligently discharges the filter capacitor only when the power supply is unplugged from the power outlet. Since the

AX-CAP® discharge circuit is disabled during normal operation, the power loss in the EMI filter can be virtually removed.

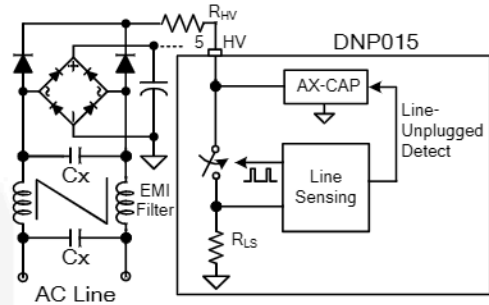

Figure 22. AX-CAP® Circuit

### Green Mode

The DNP015 modulates the PWM frequency as a function of FB voltage, as shown in Figure 23. Since the output power is proportional to the FB voltage in current-mode control, the switching frequency decreases as load decreases. In heavy-load conditions, the switching frequency is 100 kHz. Once  $V_{FB}$  decreases below  $V_{FB-N}$  (2.6 V), the PWM frequency linearly decreases from 100 kHz to 23 kHz to reduce switching losses at light-load condition. As  $V_{FB}$  decreases to  $V_{FB-G}$  (2.5 V), the switching frequency is fixed at 23 kHz.

As  $V_{FB}$  falls below  $V_{FB-ZDC}$  (2.1 V), the DNP015 enters Burst Mode, where PWM switching is disabled. Then the output voltage starts to drop, causing the feedback voltage to rise. Once  $V_{FB}$  rises above  $V_{FB-ZDCR}$ , switching resumes. Burst Mode alternately enables and disables switching, reducing switching loss to reduce power consumption, as shown in Figure 24.

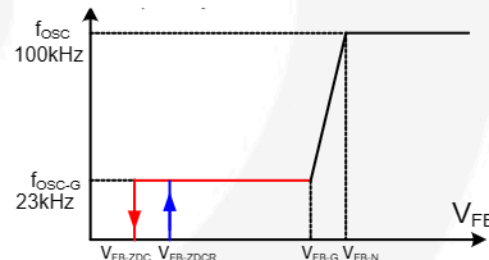

Figure 23. PWM Frequency

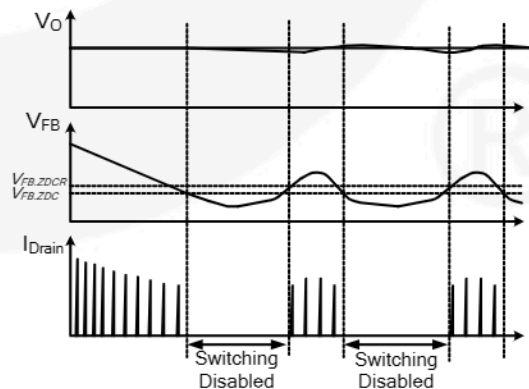

Figure 24. Burst-Mode Operation

## Protections

Protection functions include Overload / Open-Loop Protection (OLP), Over-Voltage Protection (OVP), and Over-Temperature Protection (OTP). All the protections are implemented as Latch Mode. Once the fault condition is detected, switching is terminated and the SenseFET remains off. This causes  $V_{DD}$  to fall and “hiccup” between 9 V and 12 V. As long as AC input is unplugged;  $V_{DD}$  falls to 4 V, the latch can be released, and the HV startup circuit charges  $V_{DD}$  up to 12 V voltage; allowing restart.

### Open-Loop / Overload Protection (OLP)

Because of the pulse-by-pulse current-limit capability, the maximum peak current through the SenseFET is limited and maximum input power is limited. If the output consumes more than the limited maximum power, the output voltage ( $V_O$ ) drops below the set voltage. Then the current through the opto-coupler LED and the transistor become virtually zero and FB voltage is pulled HIGH, as shown in Figure 25. If feedback voltage is above 4.6 V for longer than 56 ms, OLP is triggered.

This protection is also triggered when the feedback loop is open due to a soldering defect.

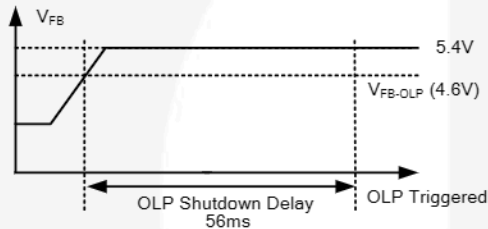

Figure 25. OLP Operation

### $V_{DD}$ Over-Voltage Protection (OVP)

If the secondary-side feedback circuit malfunctions or a solder defect causes an opening in the feedback path, the current through the opto-coupler transistor becomes virtually zero. Then feedback voltage climbs up in a similar manner to the overload situation, forcing the preset maximum current to be supplied to the SMPS until the overload protection triggers. Because more energy than required is provided to the output, the output voltage may exceed the rated voltage before the overload protection triggers, resulting in the breakdown of the devices in the secondary side. To prevent this situation, an OVP circuit is employed. Since  $V_{DD}$  voltage is proportional to the output voltage by the transformer coupling, the over voltage of output is indirectly detected using  $V_{DD}$  voltage. The OVP is triggered when  $V_{DD}$  voltage reaches 28 V. Debounce time (typically 150  $\mu$ s) is applied to prevent false triggering by switching noise.

### Over-Temperature Protection (OTP)

The SenseFET and the control IC are integrated in one package. This makes it easier for the control IC to detect the abnormal over temperature of the SenseFET. If the temperature exceeds approximately 135°C, the OTP is triggered and the MOSFET remains off.





**TRADEMARKS**

The following includes registered and unregistered trademarks and service marks, owned by Fairchild Semiconductor and/or its global subsidiaries, and is not intended to be an exhaustive list of all such trademarks.

2Cool™	FPS™		Sync-Lock™
AccuPower™	F-PFS™		
AX-CAP®*	FRFET®	PowerTrench®	TinyBoost™
BitSiC™	Global Power Resource™	PowerXS™	TinyBuck™
Build it Now™	GreenBridge™	Programmable Active Droop™	TinyCalc™
CorePLUS™	Green FPS™	QFET®	TinyLogic®
CorePOWER™	Green FPS™ e-Series™	QST™	TINYOPTO™
CROSSVOL7™	Gmax™	Quiet Series™	TinyPower™
CTL™	GTO™	RapidConfigure™	TinyPWM™
Current Transfer Logic™	IntelliMAX™		TinyWire™
DEUXPEED®	ISOPLANAR™	Saving our world, 1mW/Wk/W at a time™	TranSiC™
Dual Cool™	Making Small Speakers Sound Louder and Better™	SignalWise™	TriFault Detect™
EcoSPARK®	MegaBuck™	SmartMax™	TRUECURRENT®*
EfficientMax™	MICROCOUPLER™	SMART START™	µSerDes™
ESBC™	MicroFET™	Solutions for Your Success™	
	MicroPak™	SPM®	UHC®
Fairchild®	MicroPak2™	STEALTH™	Ultra FRFET™
Fairchild Semiconductor®	MillerDrive™	SuperFET®	UniFET™
FACT Quiet Series™	MotionMax™	SuperSOT™-3	VCX™
FACT®	mWSaver™	SuperSOT™-6	VisualMax™
FAST®	OptoHiT™	SuperSOT™-8	VoltagePlus™
FastvCore™	OPTOLOGIC®	SupreMOS®	XS™
FETBench™	OPTOPLANAR®	SyncFET™	

\* Trademarks of System General Corporation, used under license by Fairchild Semiconductor.

**DISCLAIMER**

FAIRCHILD SEMICONDUCTOR RESERVES THE RIGHT TO MAKE CHANGES WITHOUT FURTHER NOTICE TO ANY PRODUCTS HEREIN TO IMPROVE RELIABILITY, FUNCTION, OR DESIGN. FAIRCHILD DOES NOT ASSUME ANY LIABILITY ARISING OUT OF THE APPLICATION OR USE OF ANY PRODUCT OR CIRCUIT DESCRIBED HEREIN; NEITHER DOES IT CONVEY ANY LICENSE UNDER ITS PATENT RIGHTS, NOR THE RIGHTS OF OTHERS. THESE SPECIFICATIONS DO NOT EXPAND THE TERMS OF FAIRCHILD'S WORLDWIDE TERMS AND CONDITIONS, SPECIFICALLY THE WARRANTY THEREIN, WHICH COVERS THESE PRODUCTS.

**LIFE SUPPORT POLICY**

FAIRCHILD'S PRODUCTS ARE NOT AUTHORIZED FOR USE AS CRITICAL COMPONENTS IN LIFE SUPPORT DEVICES OR SYSTEMS WITHOUT THE EXPRESS WRITTEN APPROVAL OF FAIRCHILD SEMICONDUCTOR CORPORATION.

As used herein:

1. Life support devices or systems are devices or systems which, (a) are intended for surgical implant into the body or (b) support or sustain life, and (c) whose failure to perform when properly used in accordance with instructions for use provided in the labeling, can be reasonably expected to result in a significant injury of the user.
2. A critical component in any component of a life support, device, or system whose failure to perform can be reasonably expected to cause the failure of the life support device or system, or to affect its safety or effectiveness.

**ANTI-COUNTERFEITING POLICY**

Fairchild Semiconductor Corporation's Anti-Counterfeiting Policy. Fairchild's Anti-Counterfeiting Policy is also stated on our external website, [www.fairchildsemi.com](http://www.fairchildsemi.com), under Sales Support.

Counterfeiting of semiconductor parts is a growing problem in the industry. All manufacturers of semiconductor products are experiencing counterfeiting of their parts. Customers who inadvertently purchase counterfeit parts experience many problems such as loss of brand reputation, substandard performance, failed applications, and increased cost of production and manufacturing delays. Fairchild is taking strong measures to protect ourselves and our customers from the proliferation of counterfeit parts. Fairchild strongly encourages customers to purchase Fairchild parts either directly from Fairchild or from Authorized Fairchild Distributors who are listed by country on our web page cited above. Products customers buy either from Fairchild directly or from Authorized Fairchild Distributors are genuine parts, have full traceability, meet Fairchild's quality standards for handling and storage and provide access to Fairchild's full range of up-to-date technical and product information. Fairchild and our Authorized Distributors will stand behind all warranties and will appropriately address any warranty issues that may arise. Fairchild will not provide any warranty coverage or other assistance for parts bought from Unauthorized Sources. Fairchild is committed to combat this global problem and encourage our customers to do their part in stopping this practice by buying direct or from authorized distributors.

**PRODUCT STATUS DEFINITIONS**

**Definition of Terms**

Datasheet Identification	Product Status	Definition
Advance Information	Formative / In Design	Datasheet contains the design specifications for product development. Specifications may change in any manner without notice.
Preliminary	First Production	Datasheet contains preliminary data; supplementary data will be published at a later date. Fairchild Semiconductor reserves the right to make changes at any time without notice to improve design.
No Identification Needed	Full Production	Datasheet contains final specifications. Fairchild Semiconductor reserves the right to make changes at any time without notice to improve the design.
Obsolete	Not In Production	Datasheet contains specifications on a product that is discontinued by Fairchild Semiconductor. The datasheet is for reference information only.

Rev. I64